

UNEDF ab-initio progress and Plans for Year 4 & 5

- Achievements/Deliverables
 - Nuclei (^{40}Ca , ^{12}C , ...)
 - Neutron Drops and Density Functionals
 - Nuclear Scattering
 - Response
- Year 3/4 plans
- Year 5 and Major Science Challenges

Highlights / Accomplishments: CC / ^{40}Ca

Solution of the center-of-mass problem:
 Coupled-cluster wave function factorizes into Gaussian center-of-mass wave function and intrinsic state. [Hagen, Papenbrock, Dean, arXiv: 0905.3167]

$$H_{\text{cm}}(\tilde{\omega}) = T_{\text{cm}} + \frac{1}{2}mA\tilde{\omega}^2 R_{\text{cm}}^2 - \frac{3}{2}\hbar\tilde{\omega}$$

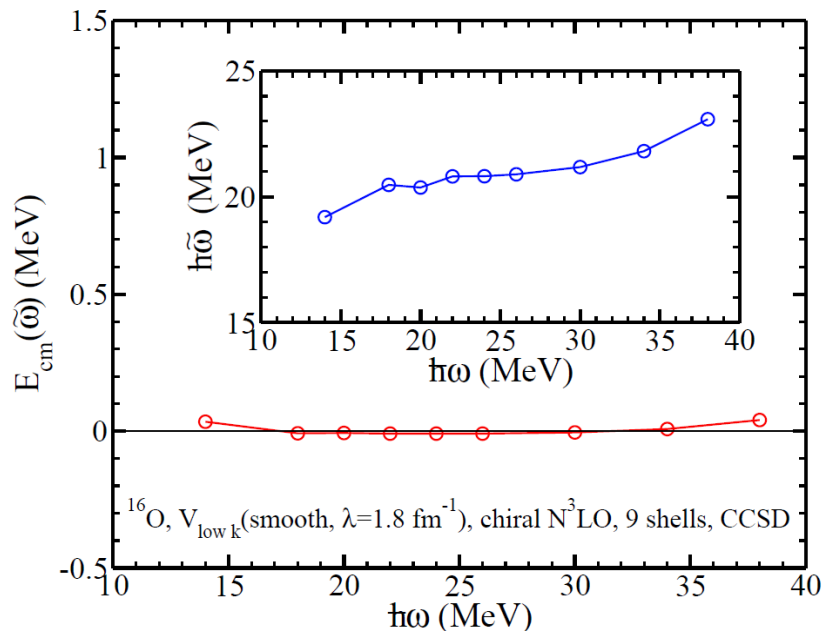

Center-of-mass energy as a function of frequency of employed oscillator basis. Inset: frequency of Gaussian center-of-mass wave function.

Saturation properties of chiral interactions:
 ^{40}Ca from a chiral nucleon-nucleon interaction within CCSD with L-triples corrections. Precision is at 2% level. [Hagen, Papenbrock, Dean, Hjorth-Jensen, Phys. Rev. Lett. 101, 092502 (2008); *ibid*, to be submitted]

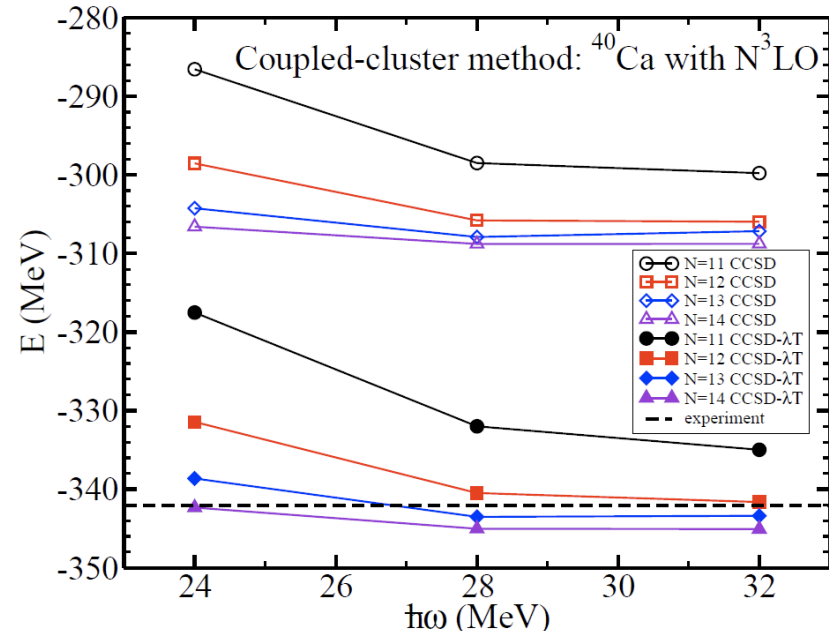

Ground-state energy of ^{40}Ca as a function of frequency of employed oscillator basis for increasing size of model space. Upper set of lines: CCSD; lower set: triples corrections.

Highlights / Accomplishments: MFDN/CI

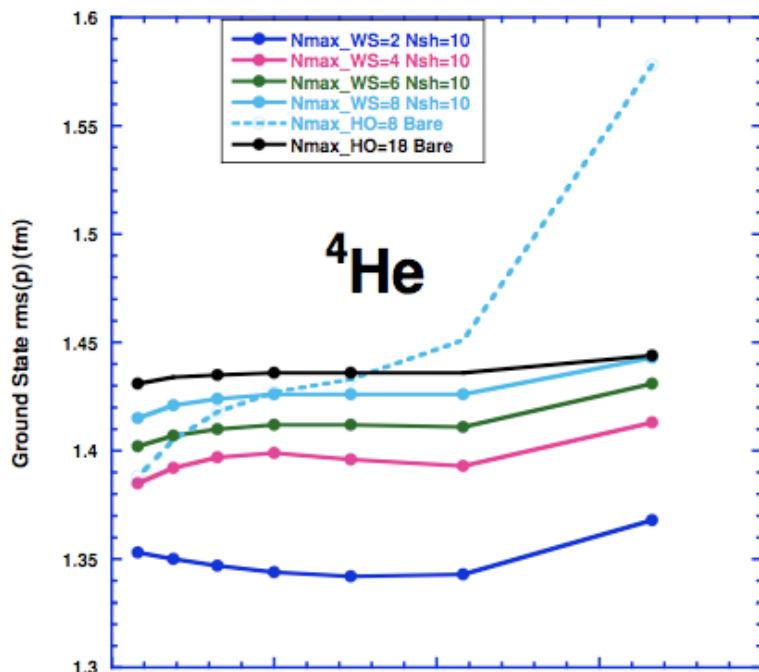
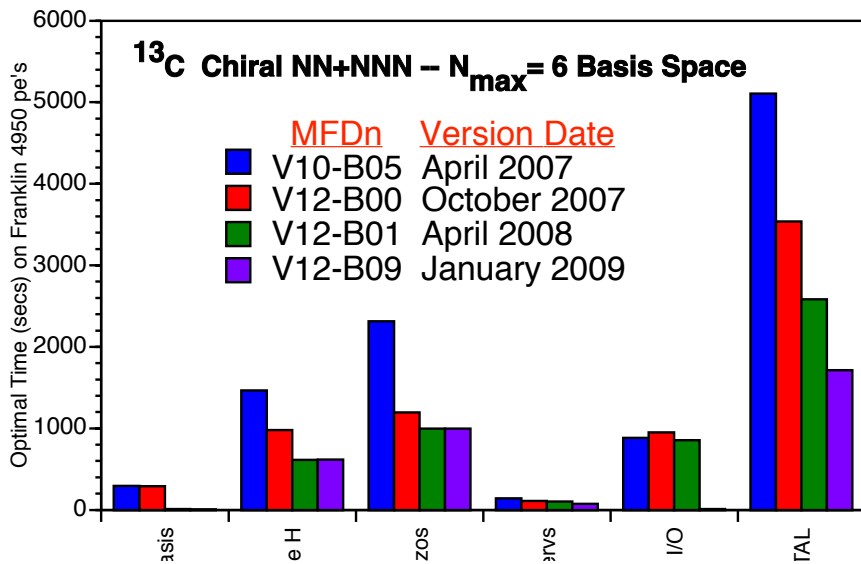

Strong Scaling

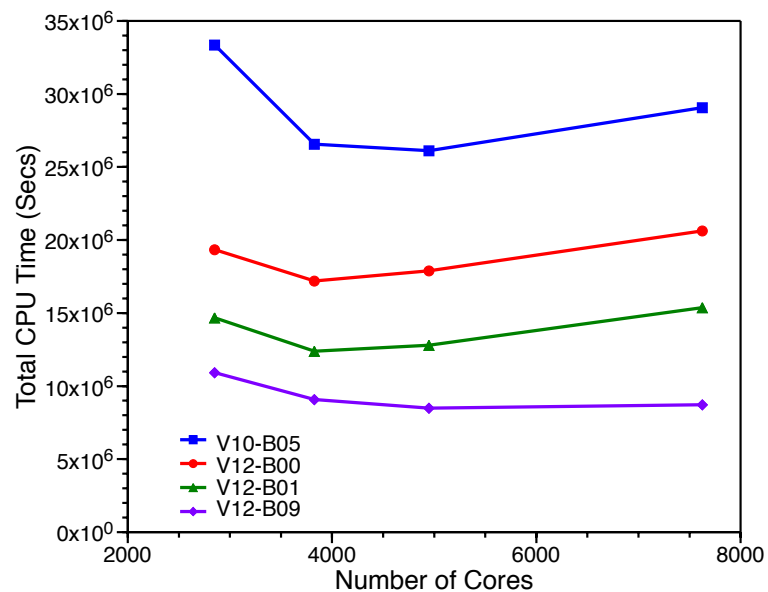

Optimized Basis

Highlights / Accomplishments: I2C / ADLB

RESULTS SO FAR

ADLB performance is very good up to 8192 nodes (32,768 cores)

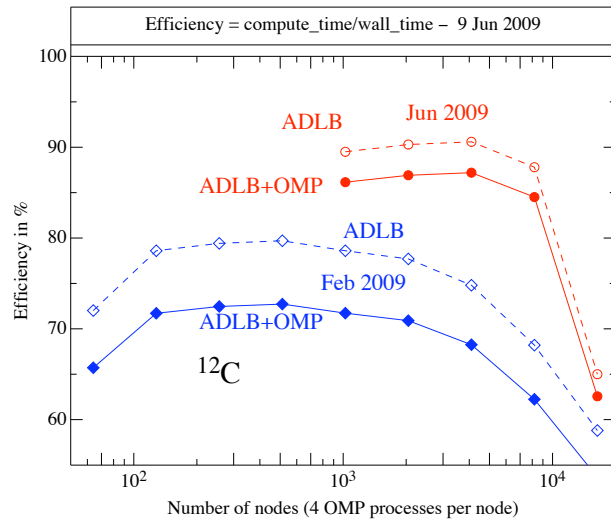

Energy

	Energy			RMS radius		
	VMC	GFMC	Expt.	VMC	GFMC	Expt.
AV18+IL7	-65.8(2)	-93.2(6)	-92.16	2.36	2.35	2.33
Modified SSCC v_8'	-74.9(2)	-94.0(5)		2.21	2.24	

Modified SSCC v_8' gives reasonable energies at least up to $A = 12$
Remember that it does not accurately reproduce NN P -phase shifts

Distributions

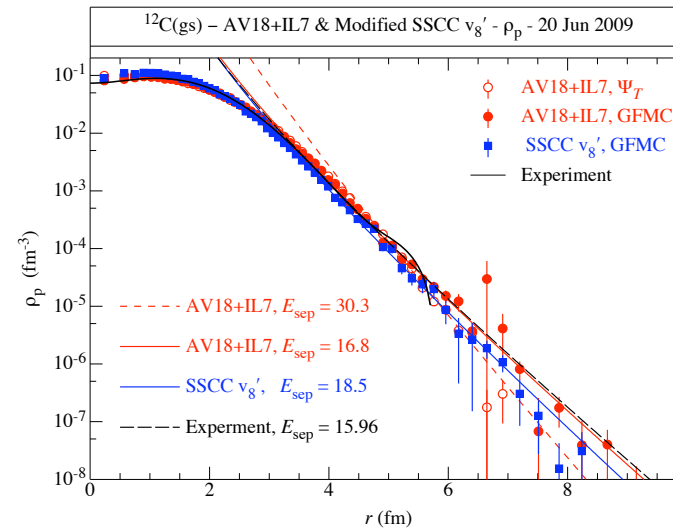
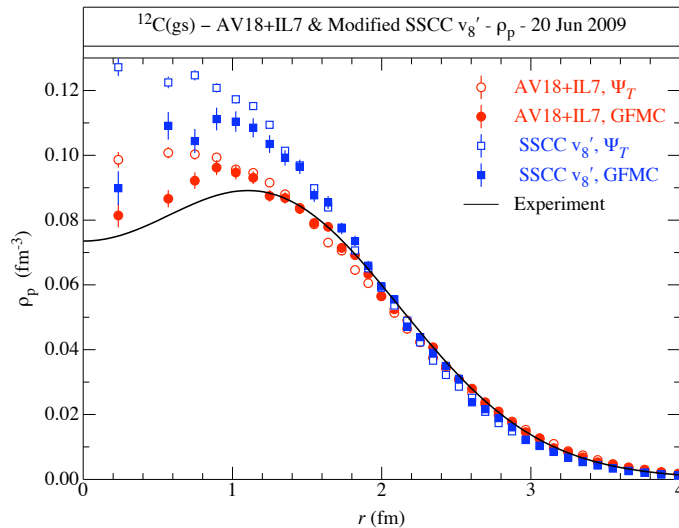

Highlights / Accomplishments: Neutron Drops

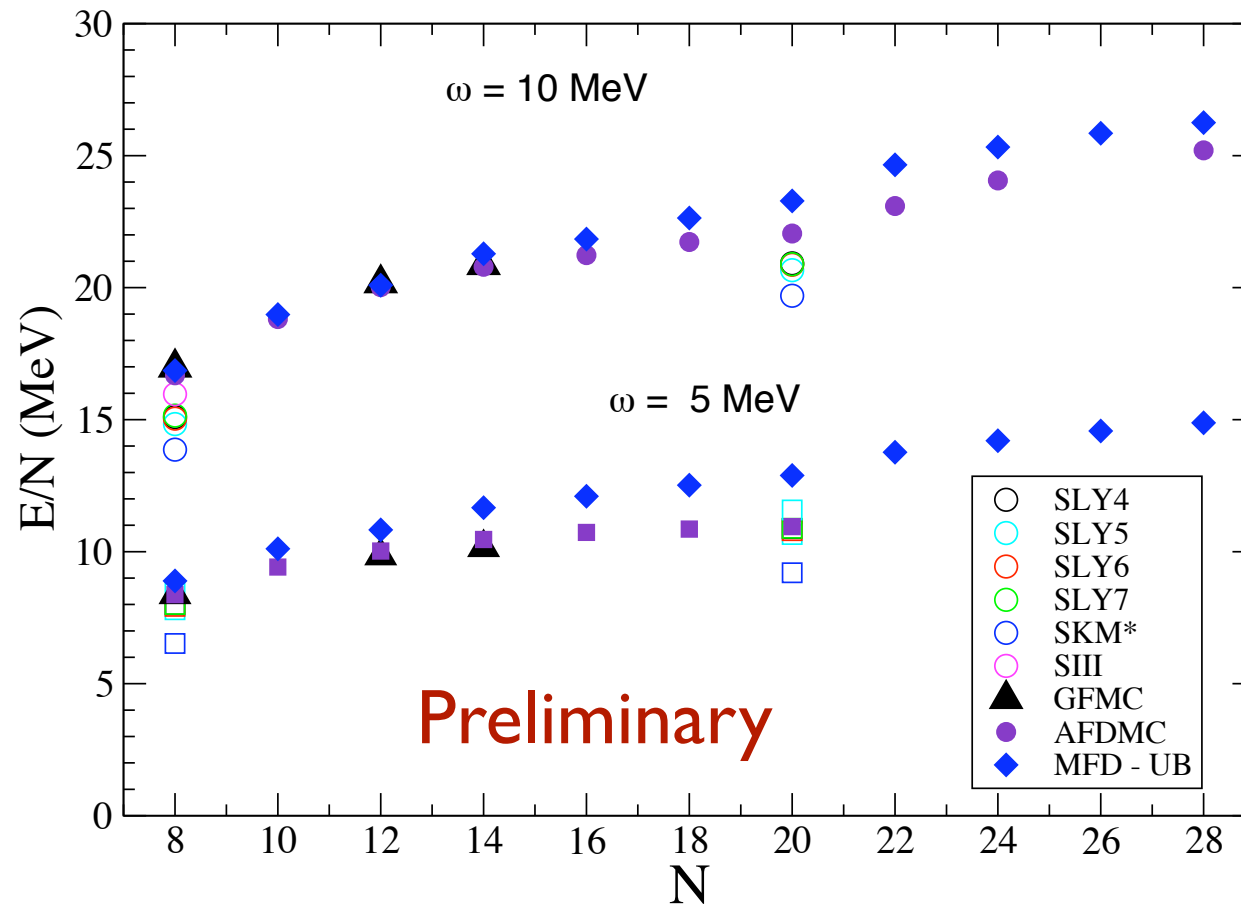

Highlights / Accomplishments: n ^7Li scattering

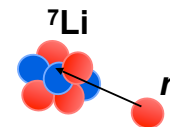

- ^7Li $3/2^-$, $1/2^-$ and $7/2^-$ states included
- Result for $N_{\text{max}}=8$ shown
- 2^+ and 1^+ states bound (slightly more)
- 0^+ and 1^+ resonances not affected
- 3^+ and 2^+ resonances appear
- Improvement of S-wave scattering length

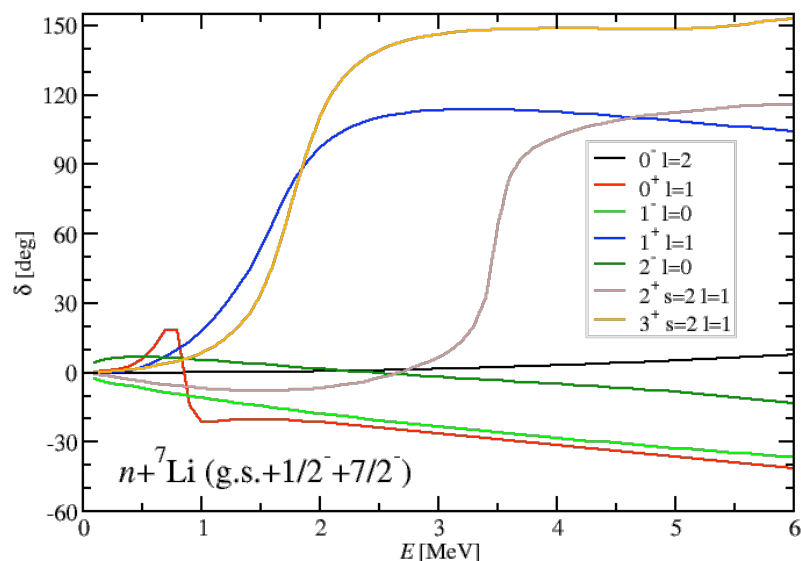
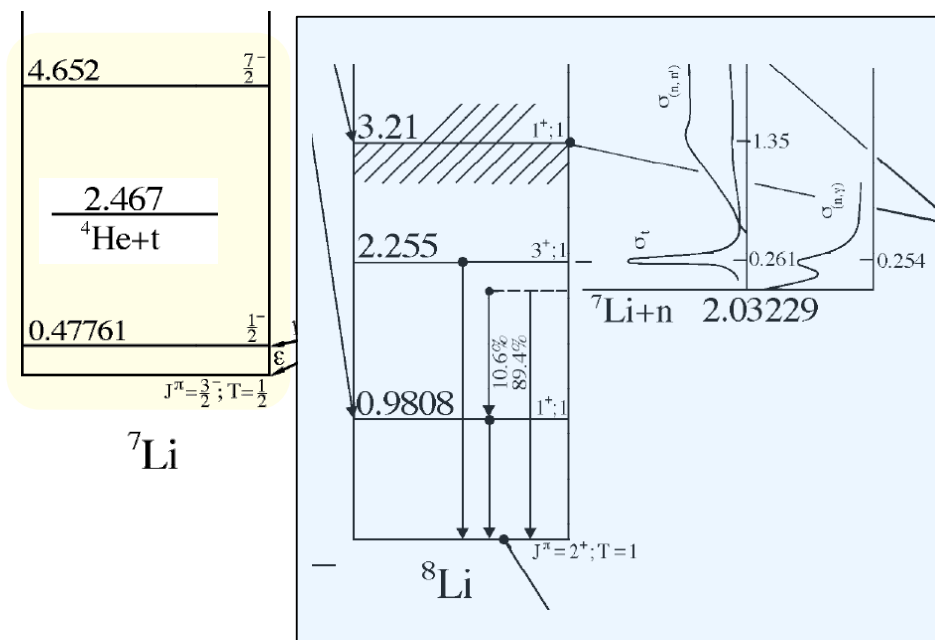

S-wave scattering length
 Expt: $a_{01}=0.87(7)$ fm
 $a_{02}=-3.63(5)$ fm
 Calc: $a_{01}=0.73$ fm
 $a_{02}=-1.42$ fm

Good match of bound states and narrow resonances with the ^8Li NCSM result.
 Predicted narrow 0^+ and 2^+ resonance. Seen at recent $p+^7\text{Be}$ FSU experiment.



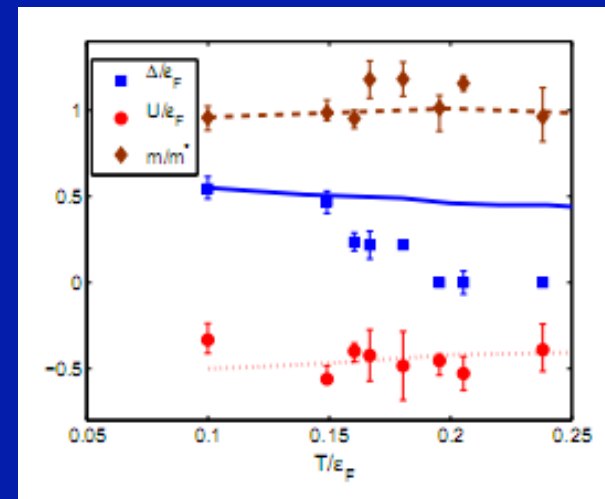
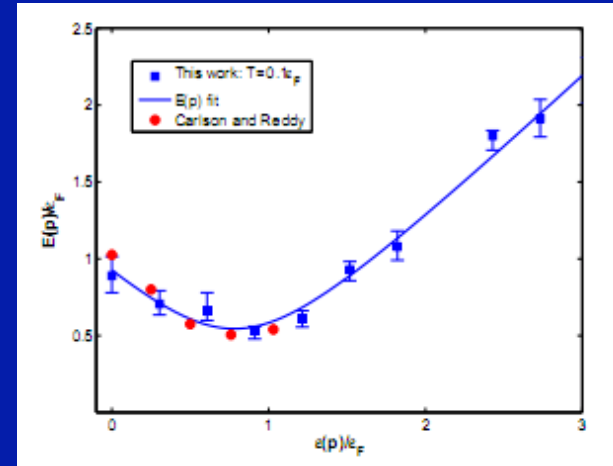
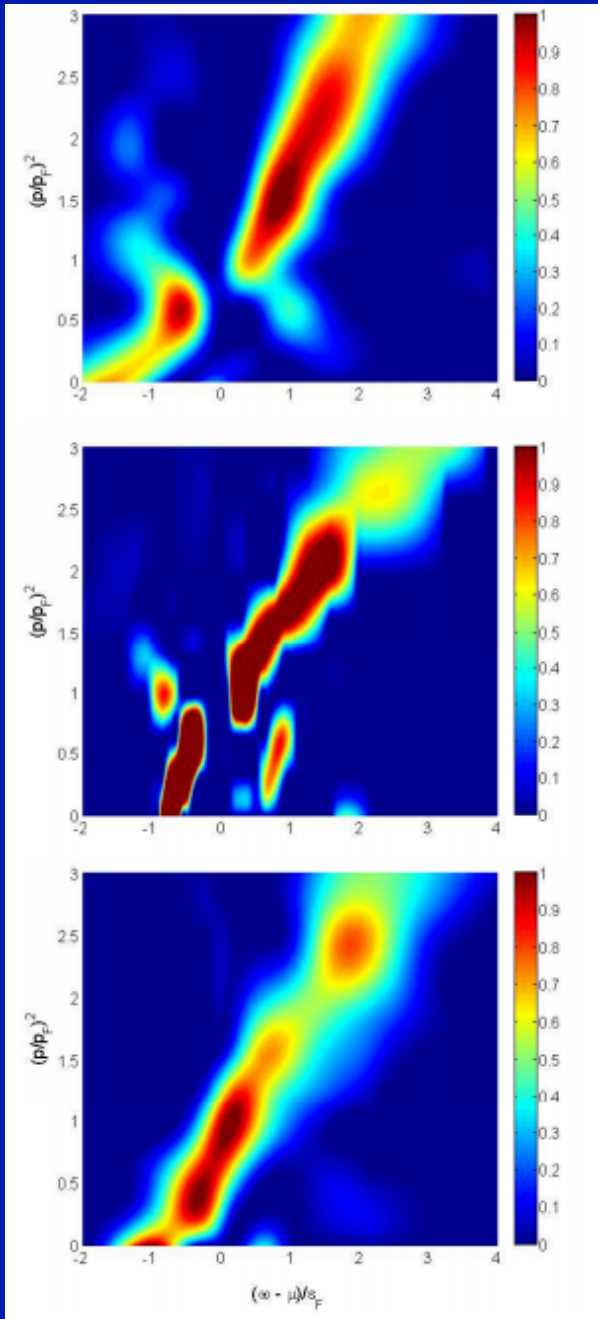

The *ab initio* calculation of the spectral weight function, quasi-particle spectrum and its properties at finite T 's.

P. Magierski, G. Wlazlowski, A. Bulgac and J.E. Drut

UNEDF ab-initio plans for year 4 (looking toward year 5)

- Nuclei
 - ^{12}C 2+ excited state and transition form factor
 - improvements to ADLB for largest computers
 - initial work toward Hoyle State
 - Cl: investigation of improved basis states and conversion
 - toward ^{14}C beta decay
- Neutron Drops, External Fields, and connections to DF
 - Finish Drops including deformation, pairing, ...
 - CC interface w/ DFT
 - initial work toward ^{40}Ca DME comparisons
- Scattering
 - n- ^7Li scattering comparisons
 - benchmarks with A=4, coupled channels in MC
 - working toward composite target, probe

High-Impact Science by Year 5

- Hoyle State in ^{12}C
- Beta Decay in ^{14}C
- DF systematic constraints from
 - neutrons
 - ^{40}Ca (CC)
 - rich external potentials, pairing, spin-orbit,...
- A=7 fusion reaction $^3\text{He}(\alpha,\gamma)^7\text{Be}$